

# Cast Steel Y Strainer to ANSI CLASS-150, 2" ~ 16"

## Series YSF-CL-150

### Features

- Simple and economical solution for water, oil and gas
- Effectively filters foreign matters in the pipeline
- May be installed in vertical or horizontal pipelines with blow-off connection at the lower end of the screen
- Various mesh size upon request
- EN10204-3.1 Material certificate available

PMA: 285 psi@34°F

TMA: 797°F

Selection:

Material of Body:  
WCB

### Standards

- Basic design to ASME B16.34
- Flange dimension acc. to ASME B16.10
- Flange dimension acc. to ASME B16.5
- Inspection & test acc. to API 598 where applicable

### Limitations

- For steam service, please inquire separately

4

### Materials List

No.	PARTS NAME	MATERIALS
1	BODY	ASTM A216 WCB
2	GASKET	SS304+Flexible Graphite
3	COVER	ASTM A216 WCB
4	SCREEN	SS304
5	DRAIN PLUG	AISI 1025
6	BOLT	ASTM A193 B7
7	NUT	ASTM A194 2H

\* Enclosed is a condensed table. For complete options, contact DIE ERSTE directly.

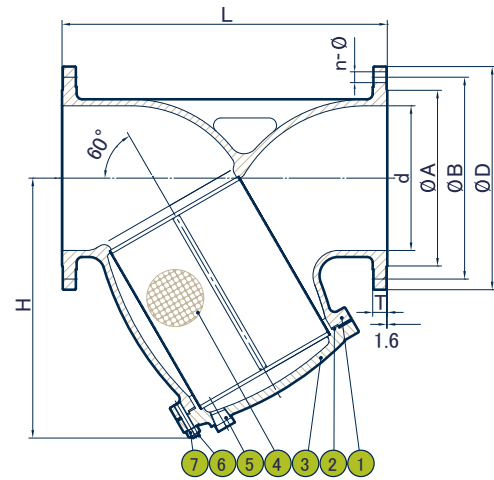

### Dimensions (mm)

Size		d	L	H	D	B	A	T	n-Ø
IN	DN								
2"	50	51	203	205	152	120.5	92	16	4-Ø19
2½"	65	64	216	230	178	139.5	105	18	4-Ø19
3"	80	76	241	255	190	152.5	127	19	4-Ø19
4"	100	102	292	300	229	190.5	157	24	8-Ø19
6"	150	152	406	390	279	241.5	216	26	8-Ø22
8"	200	203	495	490	343	298.5	270	29	8-Ø22
10"	250	254	622	550	406	362	324	31	12-Ø25
12"	300	305	698	640	483	432	381	32	12-Ø25
14"	350	337	787	720	533	476	413	35	12-Ø29
16"	400	387	914	800	597	540	470	37	16-Ø29